

PRODUCT DATASHEET

LEXAN™ MARGARD™ Soundglaze SC Sheet

DESCRIPTION

For demanding applications, such as in an urban area where antigraffiti properties are needed or in a railway station, rail track or petrol station area where higher levels of cleaning and chemical resistance are needed, then LEXAN MARGARD Soundglaze SC is the ideal choice. LEXAN MARGARD Soundglaze SC combines the impact strength of LEXAN polycarbonate with the abrasion and UV resistant properties provided by the proprietary hard coating applied to both sides of the sheet. Due to the hard coating, LEXAN MARGARD Soundglaze SC is only recommended for flat soundscreen designs, but line bending is a possible option to consider. The hard coating provides significantly improved abrasion resistance and chemical resistance to oils, paints and other fluids compared with uncoated polycarbonate. The unique coating provides a surface that can be easily cleaned, even including the removal of spray painted graffiti. LEXAN MARGARD Soundglaze SC is backed by a ten year limited warranty* against breakage and a five year limited warranty against yellowing and lost of light transmission.

* See warranties for full details

TYPICAL PROPERTY VALUES ♦

Property	Test Method	Unit	Value
Physical			
Density	ISO 1183	g/cm ³	1.20
Water absorption, 50% RH, 23 °C	ISO 62	%	0.15
Water absorption, saturation, 23°C	ISO 62	%	0.35
Mechanical			
Yield stress 50 mm/min	ISO 527	MPa	>60
Yield strain 50 mm/min	ISO 527	%	6
Nominal strain at break 50 mm/min	ISO 527	%	>100
Tensile modulus 1 mm/min	ISO 527	MPa	2300
Flexural strength 2 mm/min	ISO 178	MPa	90
Flexural modulus 2 mm/min	ISO 178	MPa	2300
Taber haze - 100 cycles, 500 gram, CS-10F	ASTM D1044	%	1 - 3
Taber haze - 500 cycles, 500 gram, CS-10F	ASTM D1044	%	3 - 8
Thermal			
Vicat softening temperature, rate B/120	ISO 306	°C	145
Temperature of deflection under load (type A), 1.8 MPa, flat	ISO 75 /Be	°C	138
Thermal conductivity	ASTM C 177	W/m°C	0.20
Coefficient of linear thermal expansion, 23-55°C	ASTM D 696	1/°C	7x10 ⁻⁵
Ball pressure test 125 ±2°C	UL 746B	°C	100
Electrical			
Volume resistivity	IEC 60093	Ohm.cm	>10 ¹⁵
Dielectric strength, in oil, 3.2 mm	IEC 60243-1	kV/mm	18
Optical			
Light transmission 2 mm	ASTM D1003	%	93
Light transmission 3 mm	ASTM D1003	%	92
Light transmission 4 mm	ASTM D1003	%	92
Light transmission 5 mm	ASTM D1003	%	91
Light transmission 6 mm	ASTM D1003	%	90
Light transmission 8 mm	ASTM D1003	%	88
Light transmission 9.5 mm	ASTM D1003	%	87
Light transmission 12 mm	ASTM D1003	%	85
Light transmission 15 mm	ASTM D1003	%	82

PRODUCT DATASHEET

LEXAN™ MARGARD™ Soundglaze SC Sheet

SOUND REDUCTION

Tests have been carried out to determine the sound reduction properties of LEXAN polycarbonate sheet. Soundglaze and Soundglaze SC provide the noise reduction and insulation properties as shown in the following tables.

Sound Transmission Class (STC dB) ISO 717 / DIN 52210

Sheet thickness	8 mm	9,5 mm	12 mm
STC	31,0 dB	32,0 dB	35,0 dB
ZTV Lsw Noise reduction*	25,9 dB	26,2 dB	28,6 dB

* Measured at highway traffic noise frequency

Acoustic insulation DIN 52210-75 Rw (dB)

Sheet thickness	8 mm	9,5 mm	12 mm
LEXAN	31 dB	32 dB	35 dB
Glass	32 dB	33 dB	34 dB

Influence of Sheet Thickness on STC (dB) ISO/17/ DIN 52210 test method

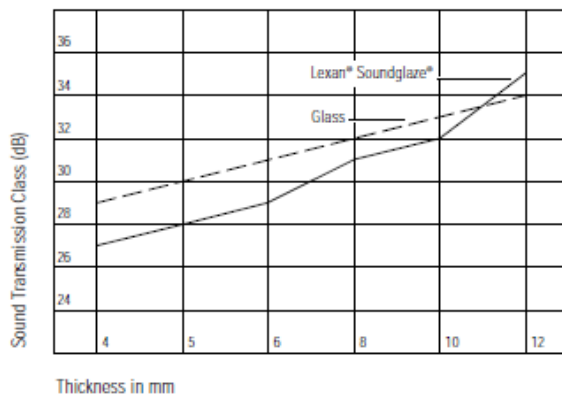

NB. ISO and DIN covers the sound frequency range from 100 Hz – 3150 Hz

FIRE PERFORMANCE

LEXAN MARGARD Soundglaze SC sheet has very good fire behavior as polycarbonate has a limiting oxygen index of 25 and so does not contribute significantly to the initiation and spread of fire, nor does it generate toxic gases.

PRODUCT AVAILABILITY

Grade	Standard size (mm)	Thickness (mm)	Standard Colour	Light transmission
LEXAN MARGARD Soundglaze SC	2000	3,4,6,8,9.5,12,15	112 – clear	89,88,87,85,84,83
UV protected and abrasion-resistant	x		5109 – bronze#	50

Alternatives are available when required.

* Typical values only - light transmission values may vary \pm 3%; details available on request.

Made to order on request, subject to minimum quantity.

PRODUCT DATASHEET

LEXAN™ MARGARD™ Soundglaze SC Sheet

Stress-strain diagram for LEXAN Solid Sheet

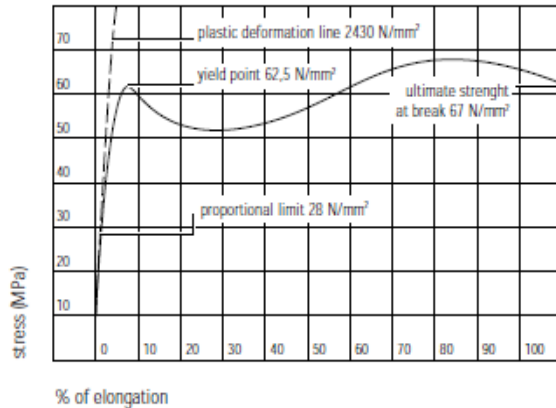

Flexural modulus vs. temperature

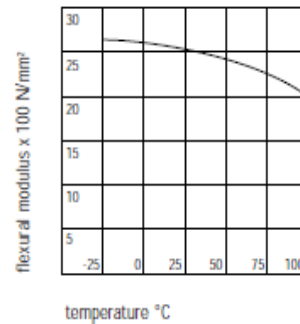

IMPACT PROPERTIES

LEXAN MARGARD Soundglaze SC is virtually unbreakable products, being up to 250 times the impact strength of glass and 30 times that of acrylic.

Comparison of LEXAN Polycarbonate Impact Strength vs. other materials (ISO 179/20 DIN 52612)

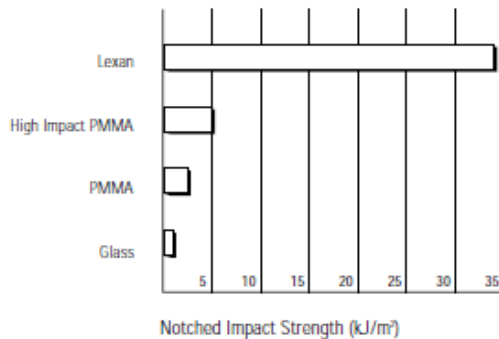

Steel Ball Impact test for security glazing: prEN 356

LEXAN polycarbonate sheet meets the highest impact performance required by the European Norm prEN 356 for security glazing. The test involves a steel ball of 4.11 kg and a diameter of 100 mm being dropped repeatedly from different heights onto the test sheet.

Category of resistance	Drop Height	Number of strikes	Code Designation	Impact energy per stroke
P1A	1500 mm	3 in a triangle	EN 356 P1A	62 Joule
P2A	3000 mm	3 in a triangle	EN 356 P2A	123 Joule
P3A	6000 mm	33 in a triangle	EN 356 P3A	247 Joule
P4A	9000 mm	3 in a triangle	EN 356 P4A	370 Joule
P5A	9000 mm	3x3 in a triangle	EN 356 P5A	370 Joule

PRODUCT DATASHEET

LEXAN™ MARGARD™ Soundglaze SC Sheet

PROJECTILE IMPACT TESTING ON LEXAN SHEETS

The test is aimed at reproducing the hazard that occurs when components or machine parts are flung out at high speed onto LEXAN sheet. The cylindrical projectile is propelled for allowing a defined impact velocity onto the test specimen.

Shooting equipment for prEN 12415 test

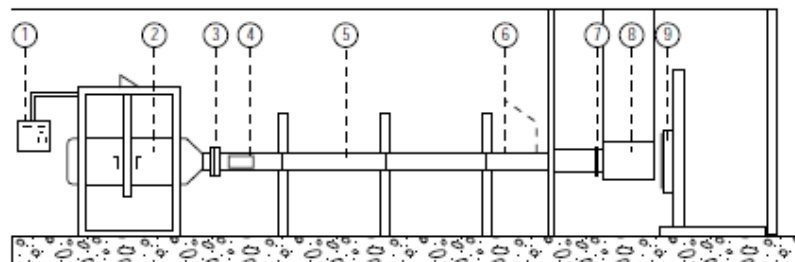

Projectile

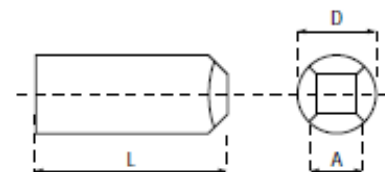

- | | |
|-----------------------------------|--------------------|
| 1 display | 6 measuring device |
| 2 pressure barrel (Pmax=10 bar) | 7 brake system |
| 3 membrane | 8 collector |
| 4 cartridge with projectile | 9 test specimen |
| 5 shooting barrel, caliber 150 mm | |

LEXAN sheet thickness	8 mm	9,5 mm	12 mm
Projectile dimensions in mm (DxLxA)	40x128x25	30x114x19	50x164x30
Projectile mass	1,25 kg	0,625 kg	2,5 kg
Projectile speed	50 m/s	80 m/s	63 m/s
Shock energy	1562 J	2000 J	4960 J

PRODUCT DATASHEET

LEXAN™ MARGARD™ Soundglaze SC Sheet

CHEMICAL RESISTANCE

LEXAN MARGARD Soundglaze SC sheet

The hard coating on LEXAN MARGARD Soundglaze SC is a highly effective chemical barrier which significantly improves its chemical resistance to a range of chemical agents that under normal circumstances would be detrimental to an uncoated LEXAN polycarbonate sheet. The comparative chemical properties between LEXAN MARGARD Soundglaze and Soundglaze SC sheet are shown in the table.

Chemicals	Exell-D	Soundglaze SC
Toluene	W/S	V
Acetone	S	V
Methylethylketone	S	V
Dichloromethane	W/S	V
Sulphuric acid (95-97%)	V	V
Hydrochloric acid (32%)	V	V
Ammonia (25%)	V	V
Thinner (Sikkens 1-2-3)	W/S	V
Super Gasoline (Esso)	W/S	V
Diesel Fuel (Esso)	V	V
Fuel C	V	V

W = surface whitening / S = surface dissolution

V = no reaction

In case of doubt about any aspect of the chemical compatibility of the LEXAN sheet range, always consult your nearest SABIC Innovative Plastics Sales Office for further information and conduct compatibility testing.

Test Certification for LEXAN Sound Barriers

IBMB extension cert. valid till 09/07/06, for original cert. 2225 / 421-2, covering stability & shape under heat & load testing for ZTV-Lsw 88 parts 3 / 4 tested on 12 mm LEXAN* sheet, clamped on two sides, and one side with a 45 degree bend.

IBMB extension valid till 09/07/06, for original cert. 2225 / 421-3, covering stability & shape under heat & load testing versus ZTV-Lsw 88 parts 7.2.3 / 4 tested on 12 mm LEXAN* sheet, clamped on two sides, and one side with a stiffener bar 500 mm from the top edge.

IBMB extension valid till 09/07/06, for original cert. 2225 / 421-4, covering stability & shape under heat & loading testing for ZTV-Lsw 88 parts 7.2.3 / 4 tested on 12 mm LEXAN* sheet, clamped on two sides and one side with a stiffener bar 1000 mm from the top edge.

ALU cert. 1040/3/83/91 of 02/05/91 covering sound reduction properties for ZTV-Lsw 88 part 7.2.1 tested on 12 mm LEXAN* sheet.

PRODUCT DATASHEET

LEXAN™ MARGARD™ Soundglaze SC Sheet

INSTALLATION GUIDELINES

Thermal Expansion Allowance

When installing LEXAN MARGARD Soundglaze SC sheet into a sound barrier frame, an allowance should be made to allow for free expansion and contraction of the sheet. In general, the thermal expansion is approximately 3 mm per linear meter.

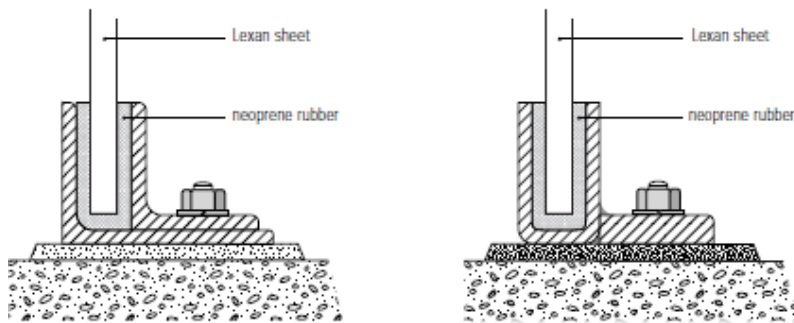

Lexan sheet fixing proposals to concrete upstand

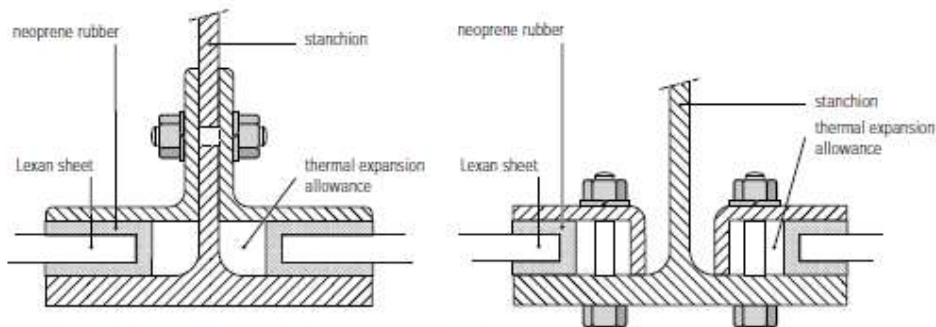

Lexan sheet fixing proposals to metal stanchions

Sheet Edge Engagement

The required sheet edge engagement for LEXAN MARGARD Soundglaze SC sheet in a sound barrier profile is approximately 25 mm.

PRODUCT DATASHEET

LEXAN™ MARGARD™ Soundglaze SC Sheet

Wind Loading Sheet Dimensions

Calculations based onto 4 sides clamped sheet into a profile system offering a sheet edge engagement of 25 mm. Maximum sheet deflection at calculated wind loading: 50 mm.

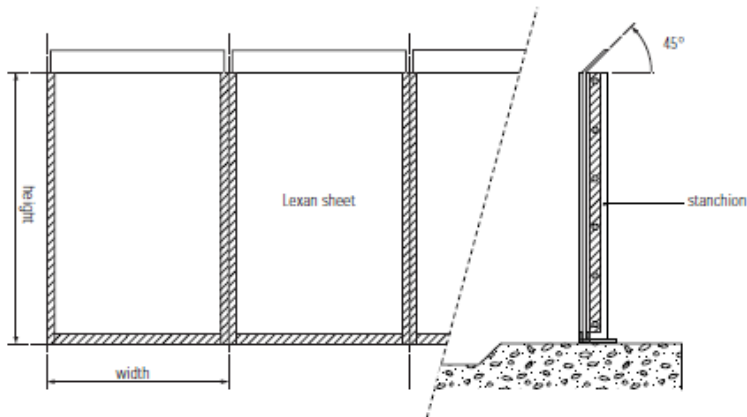

Note

If LEXAN sheet, installed as shown in the diagram above, is 3 side clamped on the bottom and both vertical sides, with the sheet top side line bent at an angle of 45 degrees, the wind load tables sheet width must be 100 mm less.

wind loading 1000 N/m²

Sheet thickness	Width	Height
8 mm	1600 mm	2000 mm
8 mm	1500 mm	2500 mm
8 mm	1400 mm	> 3000 mm
9,5 mm	2000 mm	2000 mm
9,5 mm	1750 mm	2500 mm
9,5 mm	1650 mm	> 3000 mm
12 mm	2000 mm	> 3000 mm

wind loading 1500 N/m²

Sheet thickness	Width	Height
8 mm	1400 mm	2000 mm
8 mm	1300 mm	2500 mm
8 mm	1200 mm	> 3000 mm
9,5 mm	1700 mm	2000 mm
9,5 mm	1600 mm	2500 mm
9,5 mm	1500 mm	> 3000 mm
12 mm	2000 mm	2000 mm
12 mm	1900 mm	2500 mm
12 mm	1800 mm	> 3000 mm

PRODUCT DATASHEET

LEXAN™ MARGARD™ Soundglaze SC Sheet

Gaskets / Sealants

Silicone sealants or compatible Neoprene, EPT or EPDM rubber gaskets with an approximate Shore hardness of A65 are generally recommended for use with LEXAN MARGARD Soundglaze SC sheet. Compatible reports for different rubber types are available on request. Recommended gasket systems and sealants are given in the following tables.

Recommended Sealants

Sealant	Supplier
Silpruf	GE Silicones

* more grades available

Recommended Gasket Systems

Gasket Type	Supplier
EPDM R27*, Chloropene, RZ4-35-81	Helvoet
EPDM 4330, 4431, 5530, 5331	Vredestein
EPDM 3300/670, 64470	Phoenix

* more grades available

N.B. Do Not Use PVC gasket! Due to migration of additives of soft PVC which can chemically affect LEXAN polycarbonate sheet, resulting in surface cracks or even sheet breakage.

Cleaning Recommendations

Cleaning of LEXAN MARGARD Soundglaze SC sheets after installation can be easily done on site without the need for specialist cleaning agents, unless it is to remove graffiti. Recommended procedures for general cleaning of LEXAN MARGARD Soundglaze SC sheet is given below.

Procedure 1 - Small Area

- Rinse sheet with lukewarm water.
- Wash sheet with a mild soap solution or compatible household detergent in lukewarm water, using a soft cloth or sponge to loosen any dirt and grime.
- Final rinse with cold water, and dry with a soft cloth to help prevent water spotting.

Procedure 2 - Large Areas

- Clean surface with a high pressure water and/or steam cleaner.
- Use of any cleaning additives to the water should be restricted to those compatible with LEXAN.

Point to Remember

- Do not use abrasive or highly alkaline cleaners.
- Never scrape the sheet with squeegees, razor blades or other sharp instruments.
- Do not clean sheet in hot sun or at elevated temperatures as this can lead to staining.

For special advise on cleaning or cleaners, please contact your nearest DiverseyLever office, as listed on next page opposite.

Recommended Solvent Cleaners

- White Spirit
- Petroleum Ether (BP65 deg.)

PRODUCT DATASHEET

LEXAN™ MARGARD™ Soundglaze SC Sheet

Special instructions for Cleaning Graffiti for LEXAN MARGARD Soundglaze SC sheet

The hard coating provides an effective chemical barrier, and even most graffiti such as spray paint can be easily removed.

However, to avoid damaging the coating the use of abrasive cleaners and/or cleaning implements must be avoided.

The recommended cleaning procedure for the removal of graffiti, etc., is as follows:

- Paints, marking pens, inks, lipstick, etc.: use a non abrasive graffiti remover.
- Labels, stickers: use kerosene or white spirit.
- In all instances, do a final wash with warm soap solution, followed by a rinse with clean water.

Recommended Graffiti Removers for LEXAN MARGARD Soundglaze SC sheet

Supplier	Product	Application
Chemalex	Vandalex	spray/hand
Nucoat	AG2	hand/cloth
Jumbo J.T.	Graffity	spray/hand/cloth

Cleaner & Graffiti Remover suppliers

Johnson Wax
P.O. Box 22
3640 AA Mijdrecht
The Netherlands
Tel. 0297 - 29 25 00
Fax 0297 - 29 25 90

Jumbo Totaal bv
Achterzeedijk 57
2992 SB Barendrecht
The Netherlands
Tel. 0180 - 61 90 09
Fax 0180 - 61 94 73

DiverseyLever AG
CH-9542 Münchwilen
Switzerland
Tel. 071 - 969 27 27

DiverseyLever
Calle Rosselon 174-176
08036 Barcelona
Spain
Tel. 93 - 323 10 54

Nucoat
Dudley road
Wolverhampton
UK
Tel. 0902 - 33 65 65
Fax 0902 - 33 73 51

Chemalex
432 Hillington Road
Glasgow G52 4BL
UK
Tel. 041 - 882 - 9938
Fax 041 - 810 - 5163

DiverseyLever
Wienerbergstrasse 7
A-1103 Vienne
Austria
Tel. 01 - 60 55 70

DiverseyLever Divizia
Odborárska 52
Sk-831 02 Bratislava
Slovakia
Tel. 07 - 501 29 88
Tel. 07 - 525 48 95

DiverseyLever SRO
Táborská 5/979
140 00 Praha 4
Czech Republic
Tel. 02 - 61 22 25 24

DiverseyLever AB
Röntgenvägen 3
S-14152 Huddinge
Sweden
Tel. 08 - 779 93 00

DiverseyLever
Jamestown Road
Finglas
Dublin 11
Ireland
Tel. 01 - 836 19 66

DiverseyLever A/S
Smedenholm 3-5
DK-2730 Herlev
Denmark
Tel. 044 - 85 61 00

DiverseyLever
Haachtsteenweg 672
B-1910 Kampenhout
Belgium
Tel. 016 - 61 77 77

DiverseyLever France
9-11, Avenue du Val de
Fontanay
94133 Fontanay Sous Bois
France
Tel. 01 - 45 14 76 76

DiverseyLever (Offices)
Via Meucci 40
20128 Milan
Italy
Tel. 02 - 258 01

DiverseyLever Sp. z.o.o.
UI Zupnica 17
03-821 Warsaw
Poland
Tel. 022 - 670 24 32

DiverseyLever
Rautatienkarn 9-11
FIN-20200 Turku
Finland
Tel. 02 - 269 72 22

DiverseyLever
General Offices
Weston Favell Centre
Northampton NN3 8PD
United Kingdom
Tel. 01604 - 40 53 11

DiverseyLever
Mallaustrasse 50-56
Postfach 81 03 60
D-68219 Mannheim
Germany
Tel. 0621 - 875 70

DiverseyLever
Maarssebroeksedijk 2
3606 AN Maarsse
The Netherlands
Tel. 030 - 247 69 11

PRODUCT DATASHEET

LEXAN™ MARGARD™ Soundglaze SC Sheet

Americas Headquarters

SABIC Innovative Plastics
One Plastics Avenue
Pittsfield, MA 01201
USA
T +1-413-448-7125
Toll-free: 1-800-323-3783
F +1 (888) 443-2033
sfscustomerservice@sabic-ip.com

European Headquarters

SABIC Innovative Plastics
Plasticslaan 1
4612 PX
Bergen op Zoom
The Netherlands
T +31 164 293684
F +31 164 293272
Sfs.info@sabic-ip.com

Pacific Headquarters

SABIC Innovative Plastics
Specialty Film & Sheet
1266 Nanjing Road (W)
16th Floor, Plaza 66
200040 Shanghai
China
T +86 21 62881088 ext. 6733
F +86 21 6288 0818

E-mail

sfscustomerservice@sabic-ip.com



* Trademark of SABIC Innovative Plastics IPPI

THE MATERIALS, PRODUCTS AND SERVICES OF SABIC INNOVATIVE PLASTICS HOLDING BV, ITS SUBSIDIARIES AND AFFILIATES ("SELLER"), ARE SOLD SUBJECT TO SELLER'S STANDARD CONDITIONS OF SALE, WHICH CAN BE FOUND AT <http://www.sabic-ip.com> AND ARE AVAILABLE UPON REQUEST. ALTHOUGH ANY INFORMATION OR RECOMMENDATION CONTAINED HEREIN IS GIVEN IN GOOD FAITH, SELLER MAKES NO WARRANTY OR GUARANTEE, EXPRESS OR IMPLIED, (i) THAT THE RESULTS DESCRIBED HEREIN WILL BE OBTAINED UNDER END-USE CONDITIONS, OR (ii) AS TO THE EFFECTIVENESS OR SAFETY OF ANY DESIGN INCORPORATING SELLER'S PRODUCTS, SERVICES OR RECOMMENDATIONS. EXCEPT AS PROVIDED IN SELLER'S STANDARD CONDITIONS OF SALE, SELLER SHALL NOT BE RESPONSIBLE FOR ANY LOSS RESULTING FROM ANY USE OF ITS PRODUCTS OR SERVICES DESCRIBED HEREIN. Each user is responsible for making its own determination as to the suitability of Seller's products, services or recommendations for the user's particular use through appropriate end-use testing and analysis. Nothing in any document or oral statement shall be deemed to alter or waive any provision of Seller's Standard Conditions of Sale or this Disclaimer, unless it is specifically agreed to in a writing signed by Seller. No statement by Seller concerning a possible use of any product, service or design is intended, or should be construed, to grant any license under any patent or other intellectual property right of Seller or as a recommendation for the use of such product, service or design in a manner that infringes any patent or other intellectual property right.
SABIC Innovative Plastics is a trademark of SABIC Holding Europe BV

™ Trademark of SABIC.

sabic-ip.com/sfs