

# Karosseri profilsystemer

kapittel 4

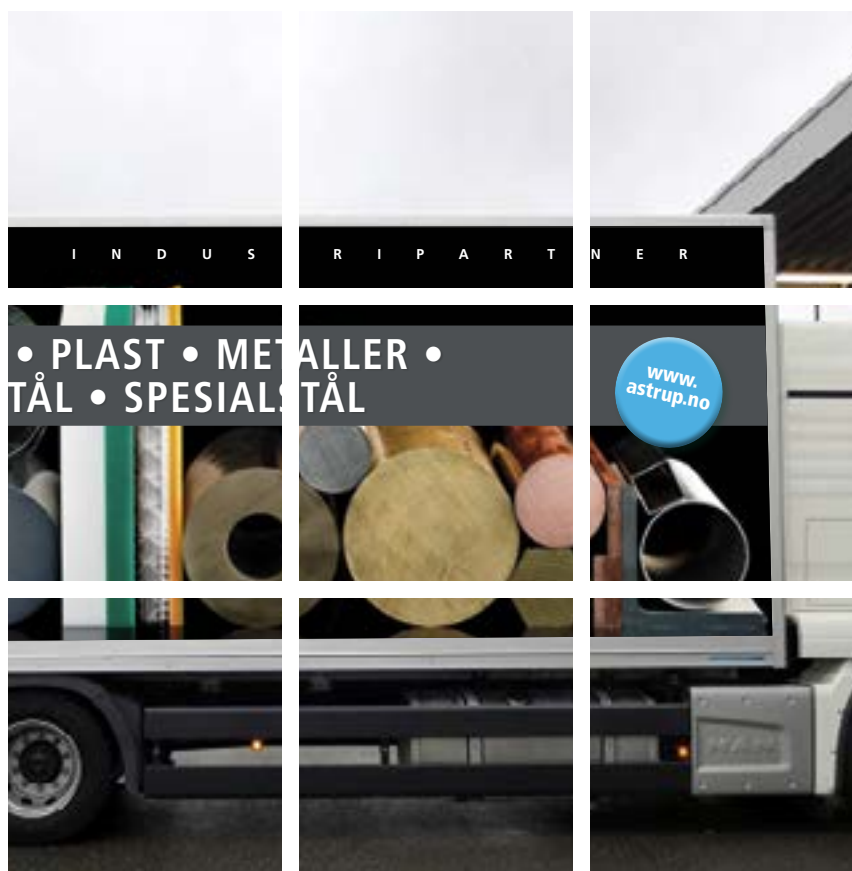

Stykkogods lemprofiler –		Vannlist og pakning	
System BW25 Snaplock	76	for bakløfter	88
Byggprofiler –		Sidehinder /	
System BW25 Eurosnap	78	Underkjøringshinder	89
Stykkogods lemprofiler	79	Kjørebrosystem LA og LVA	93
Tilbehør til Stykkogodslemmer	80	Kjørebro type LVA	
Låser og hengsler	81	(med forsterket profil)	94
Stykkogods planbunnprofiler	82	Kjørebro type LA	
Aluminium Sliteplate, glatt	85	(uten forsterket profil)	94
Aluminium Dørkplater		Øvrige produkter	95
Riskorn	85		
Tippelemprofiler			
– System Astrup	85		
Tilbehør Tipplemmer	86		
Skappåbygg profiler	87		





## STYKKGODS LEMPROFILER – SYSTEM BW25 SNAPLOCK

Eloksert og ueloksert

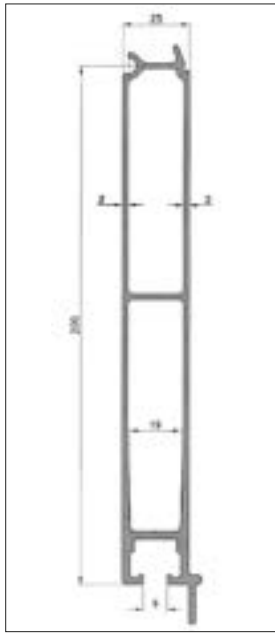

Profilnavn: Bunnprofil 25/200  
 Profilnr.: K11987  
 Vekt: 3,11 kg/m

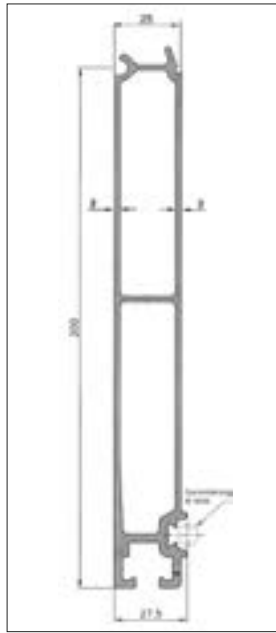

Profilnavn: Bunnprofil 25/200  
 Profilnr.: K11988  
 Vekt: 3,00 kg/m

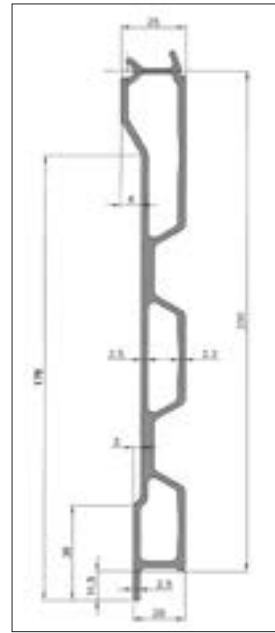

Profilnavn: Bunnprofil 25/200  
 Profilnr.: K14845  
 Vekt: 3,23 kg/m

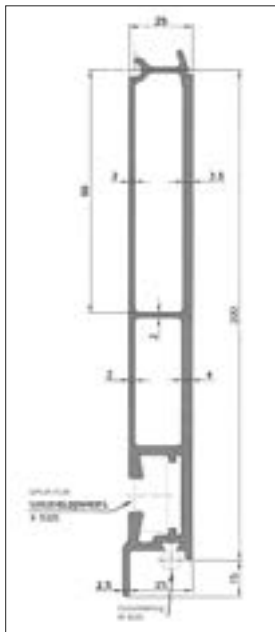

Profilnavn: Bunnprofil 25/200  
 Profilnr.: K16898  
 Vekt: 4,01 kg/m

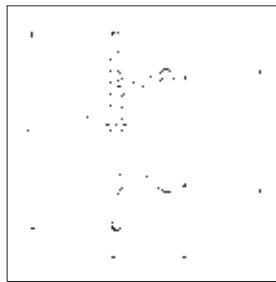

Profilnr.: K29200  
 Vekt: 0,12 kg/m

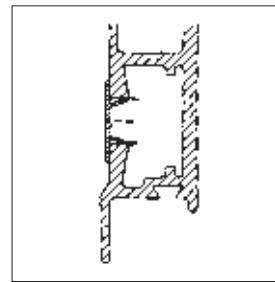

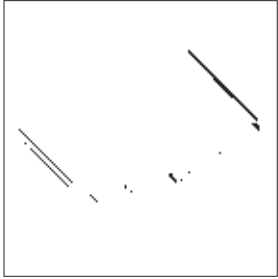

Monteringsanvisning  
Snap-lock-lemmer

## Elokstert og uelokstert

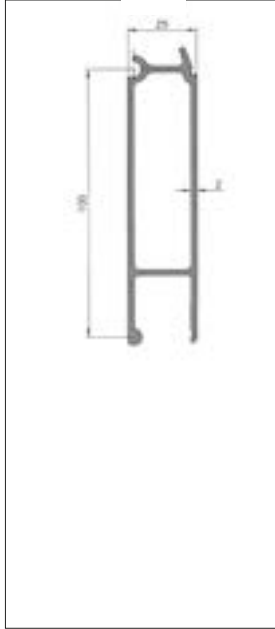

Profilnavn: Mellomprofil  
25/100  
Profilnr.: K7016  
Vekt: 1,52 kg/m

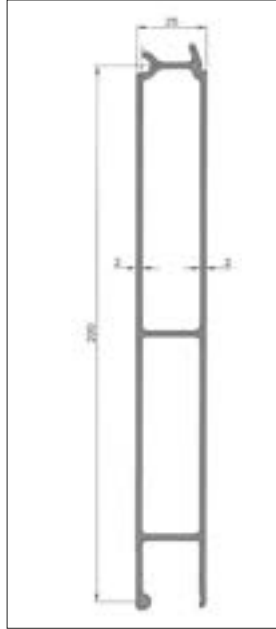

Profilnavn: Mellomprofil  
25/200  
Profilnr.: K7652  
Vekt: 2,70 kg/m

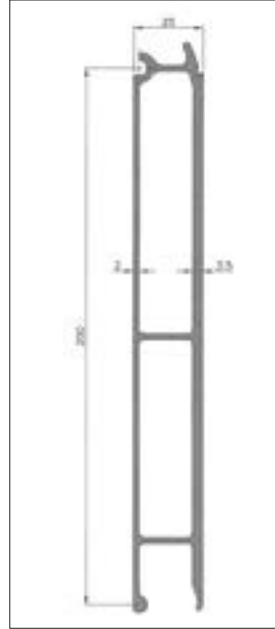

Profilnavn: Mellomprofil  
25/200  
Profilnr.: K15993  
Vekt: 3,48 kg/m

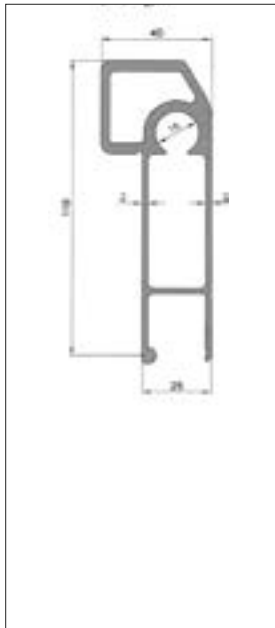

Profilnavn: Topprofil  
25/200  
Profilnr.: K16838  
Vekt: 2,35 kg/m

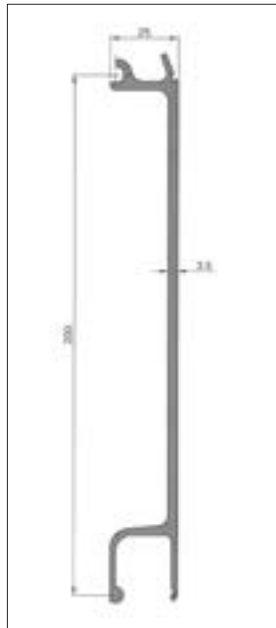

Profilnavn: T.I.R. Profil  
25/200  
Profilnr.: K7653  
Vekt: 2,40 kg/m

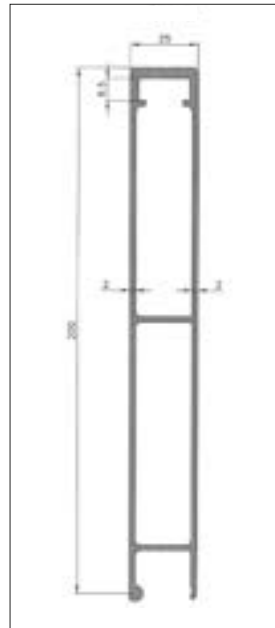

Profilnavn: Topprofil  
25/200  
Profilnr.: K8269  
Vekt: 2,60 kg/m

## BYGGPROFILER – SYSTEM BW25 EUROSAP

---

### Ueloksert

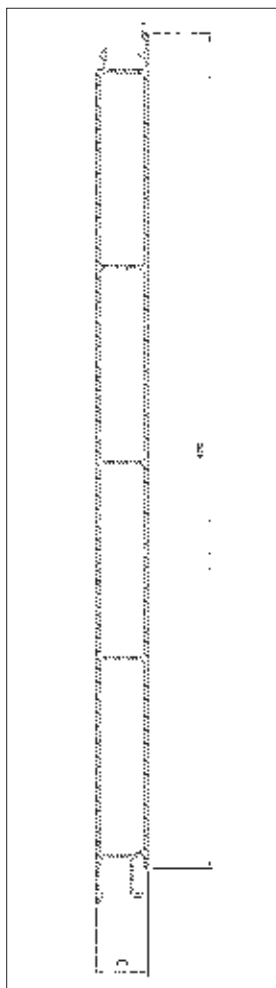

Profilnavn: Mellomprofil  
25/400

Profilnr.: K19127

Vekt: 5,27 kg/m

## STYKKGODS LEMPROFILER

### Eloksert og ueloksert

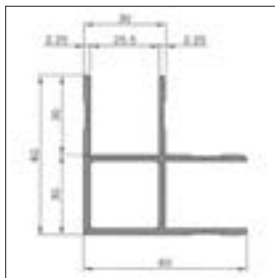

Profilnavn: Hjørneprofil  
 Profilnr.: K10401  
 Vekt: 1,40 kg/m

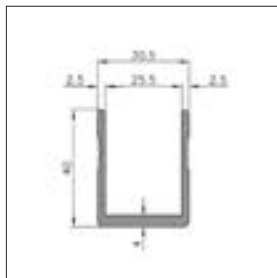

Profilnavn: Endeprofil  
 Profilnr.: K7023  
 Vekt: 0,81 kg/m

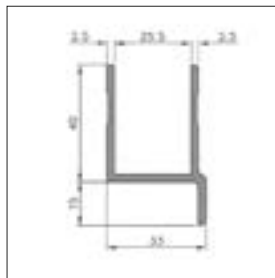

Profilnavn: Endeprofil  
 Profilnr.: K7028  
 Vekt: 0,84 kg/m

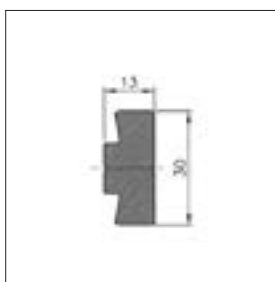

Profilnavn: Skruholderprofil  
 Profilnr.: K15325  
 Vekt: 0,89 kg/m

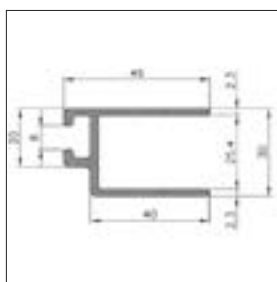

Profilnavn: Dørromrammingsprofil  
 Profilnr.: K10201  
 Vekt: 0,,84 kg/m



Profilnavn: Gummipakning  
 Profilnr.: TD-KAP-25  
 For profil K10201

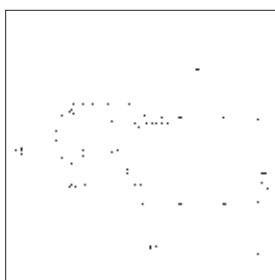

Profilnavn: Endelist  
 Profilnr.: XTR 0631  
 Vekt: 1,58 kg/m

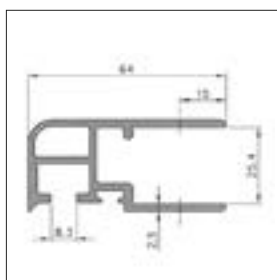

Profilnavn: Endeprofil  
 Profilnr.: XTR 0634  
 Vekt: 1,26 kg/m

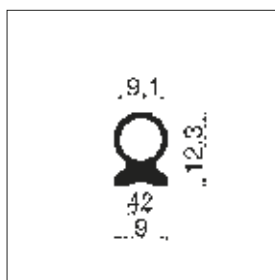

Profilnavn: Gummipakning  
 Profilnr.: 293-G140  
 For XTR 0631 og XTR 0634

## Eloksert og ueloksert



Profilnavn: Endepofil med spor for innfesting av kinnegrippøye

Profilnr.: 4T-658

Vekt: 1,26 kg/m

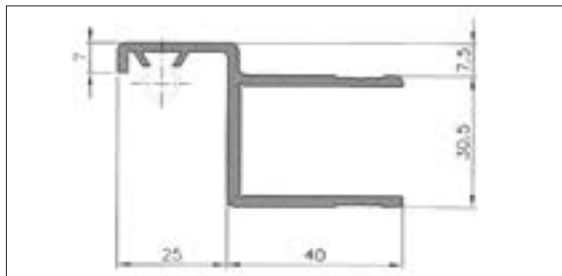

Profilnavn: Dørrammings profil

Profilnr.: K11072

Vekt: 0,97 kg/m

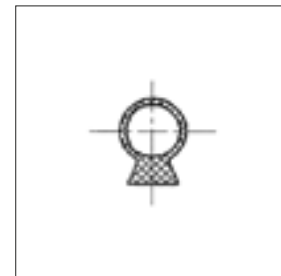

Profilnavn: Gummipakning

Profilnr.: W4529

For K11072 og 4T-658

## TILBEHØR TIL STYKKGODSLEMMER

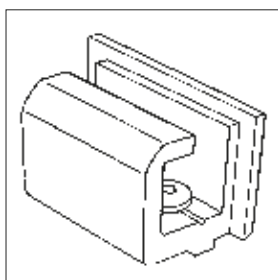

Profilnavn: Kinnegripøye

i aluminium, eloksert

Profilnr.: K5

Passer til profil 4T-658

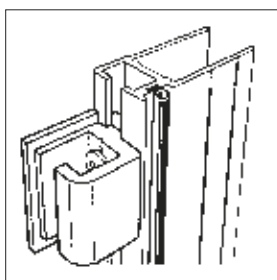

Profilnavn: Kinnegripøye stål

Profilnr.: K20

Passer til profil XTR 0631

og XTR 0634

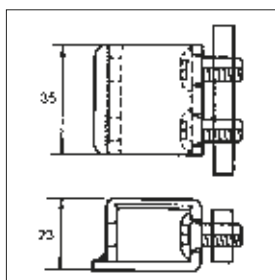

## LÅSER OG HENGSLER

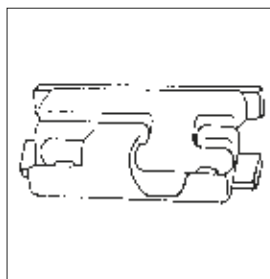
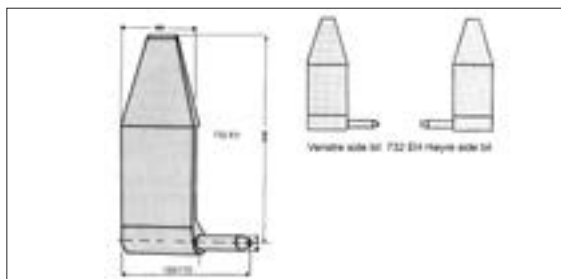

Eloksert Aluminium Hengsel  
 Tilpasset profil K14845 i stykkgoods lemsystem BW-25  
 Kan også anvendes til andre systemer  
 Leveres med 70 og 90 mm tapp

Profilnavn: T.I.R. Stålhengsel  
 Profilnr.: 1513  
 Vekt: 0,85 kg/stk.  
 Passer til profil  
 K11987 og K11988

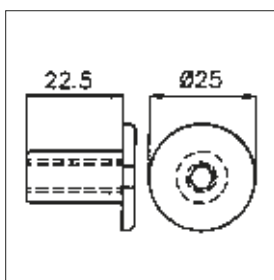

M8 x 22 Hylsemutter

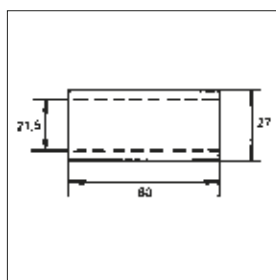

Lagerhylse, stål

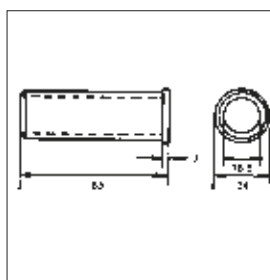

Lagerhusing, nylon

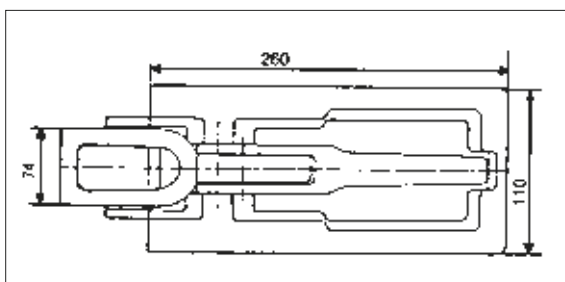

Profilnavn: Lemlås  
 Profilnr.: H 206 N  
 Vekt: 1,64 kg/stk.

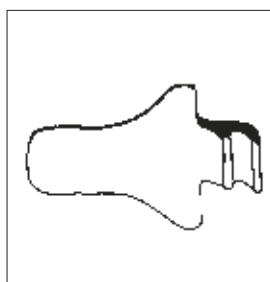

Profilnavn: Mothold  
 Profilnr.: P-W 1004  
 Til lemlås P-W 2001

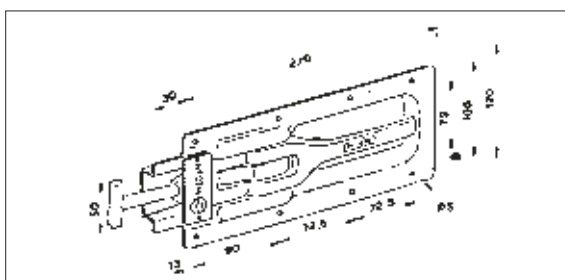

Profilnavn: Lemlås  
 Profilnr.: P-W 2001  
 Vekt: 0,80 kg/stk.

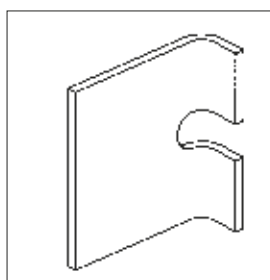

Profilnavn: Mothold  
 til lemlås H 206 N

## STYKKGODS PLANBUNNPROFILER

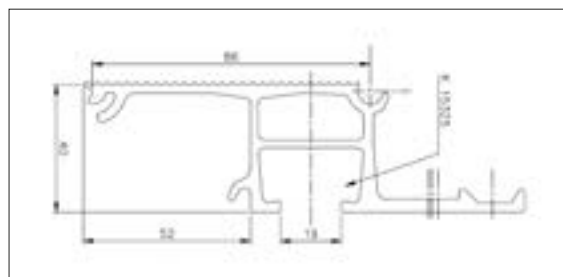
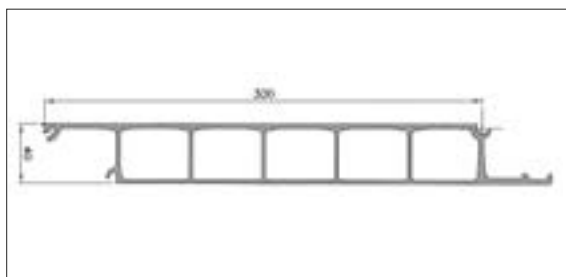
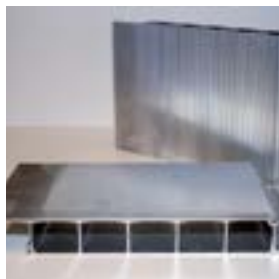

Profilnavn: Planbunnprofil

Profilnr.: K27231

Vekt: 6,37 kg/m

$I_x = 65,298 \text{ cm}^4$

$W_x = 30,844 \text{ cm}^3$

Profilnavn: Koblingsprofil

Profilnr.: K27232

Vekt: 2,47 kg/m

$I_x = 20,809 \text{ cm}^4$

$W_x = 10,125 \text{ cm}^3$

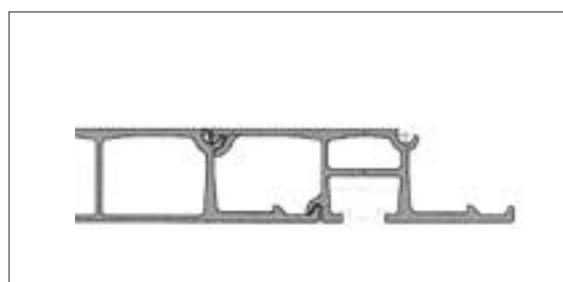
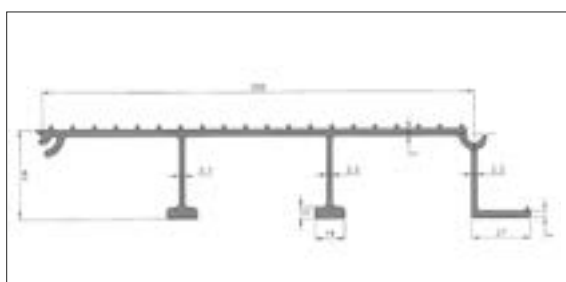

Profilnavn: Planbunnprofil, riflet

Profilnr.: K7654

Vekt: 3,30 kg/m

$I_x = 26,06 \text{ cm}^4$

$W_x = 9,31 \text{ cm}^3$



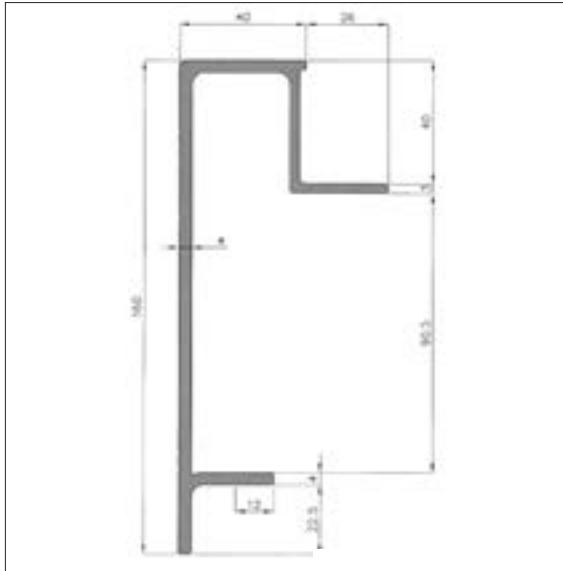

Profilnavn: Kantrammeprofil  
 Profilnr.: 4T-810  
 Vekt: 2,95 kg/m  
 Tilpasset: 25 mm lemsystem  
 90 mm tverrbjelke  
 Hjørneprofil K13915  
 Undermontert hengsel 1513

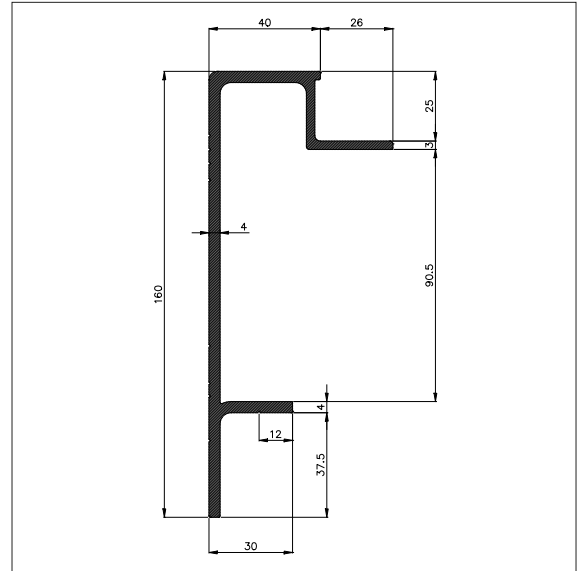

Profilnavn: Kantrammeprofil  
 Profilnr.: 4T-811  
 Vekt: 2,82 kg/m  
 Tilpasset: 25 mm lemsystem  
 90 mm tverrbjelke  
 Hjørneprofil K13915  
 Undermontert hengsel 1513

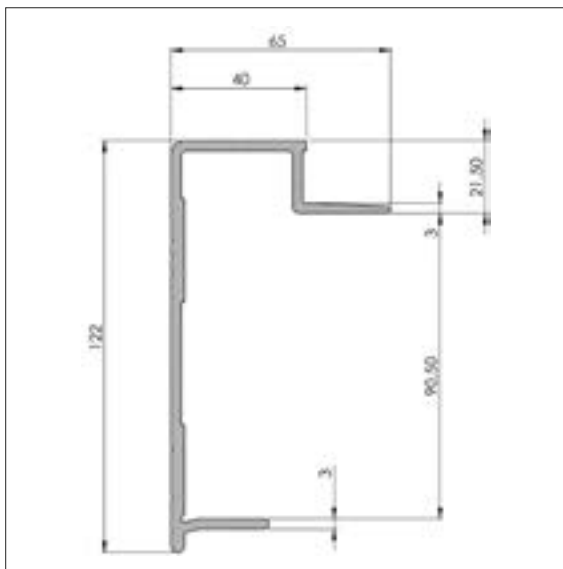

Profilnavn: Kantrammeprofil  
 Profilnr.: K13913  
 Vekt: 1,98 kg/m  
 Tilpasset: 25 mm lemsystem  
 90 mm tverrbjelke  
 Hjørneprofil K13915  
 Undermontert hengsel 1513

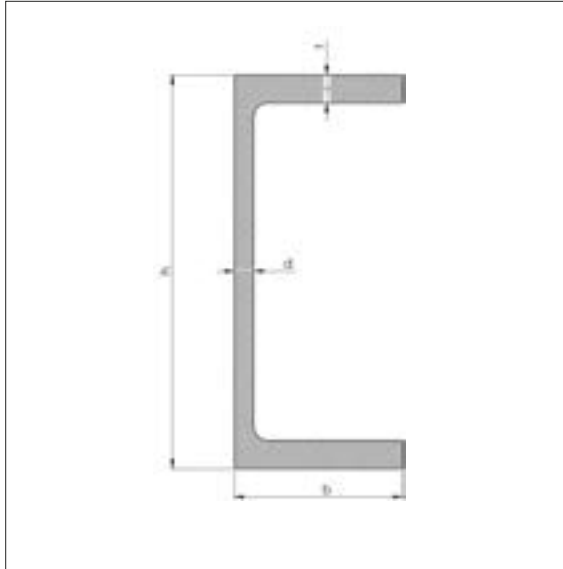

Profilnavn: Aluminium  
U-profil  
Hjelperammer

Dimensjon h × b × d × t	Vekt kg/m
140 × 60 × 7 × 10	5,71
200 × 60 × 4,5 × 8	5,00

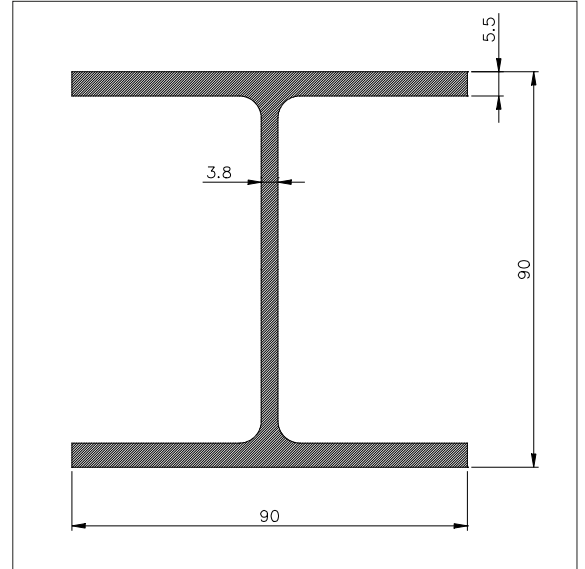

Profilnavn: Tverrdrager  
Profilnr.: 4T-806  
Vekt: 3,54 kg/m  
 $I_x = 196 \text{ cm}^4$   
 $W_x = 43,6 \text{ cm}^3$

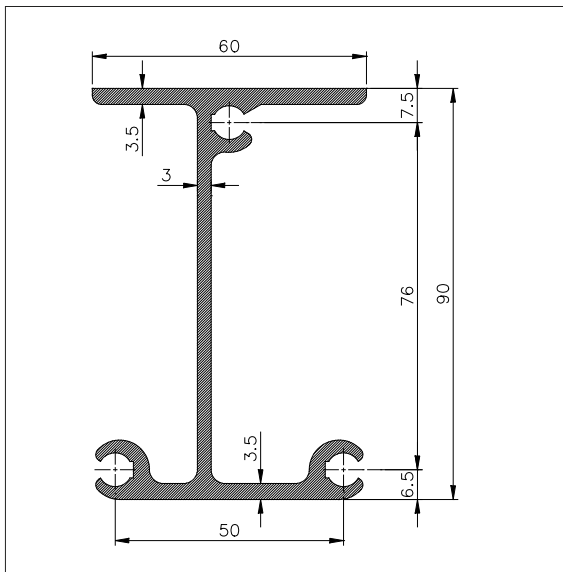

Profilnavn: Tverrdrager  
Profilnr.: K13914  
Vekt: 2,17 kg/m  
Skruespor for M8  
 $I_x = 109,34 \text{ cm}^4$   
 $W_x = 23,11 \text{ cm}^3$

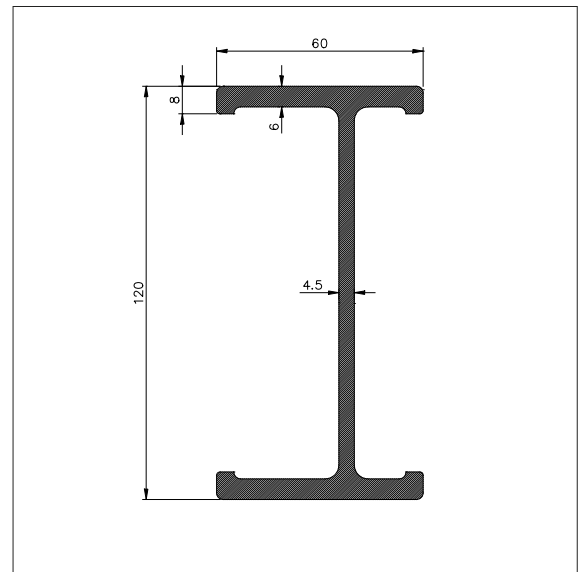

Profilnavn: Oppbygging-/tverrdrager  
Profilnr.: K5595  
Vekt: 3,50 kg/m  
 $I_x = 296,03 \text{ cm}^4$   
 $W_x = 49,34 \text{ cm}^3$

## ALUMINIUM SLITEPLATE, GLATT

### 5086 – H22

Tykkelse mm	Format mm	Vekt kg/plate
5,0	2500 × 6000	210,0

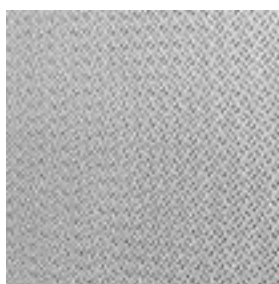

## ALUMINIUM DØRKPLATER RISKORN

### EN-AW 5086/5754, primet bakside

Tykkelse mm	Format mm	Tilstand/ Legering	Vekt kg/plate
*2,0/2,5	1250 × 2500	H24/5754	18,4
2,7/3,2	2500 × 8000	H244/5086	153,0

\* Ikke primet bakside

Mønster Riskorn  
Mønsterhøyde ca. 0,5 m

## TIPPELEMPROFILER – SYSTEM ASTRUP

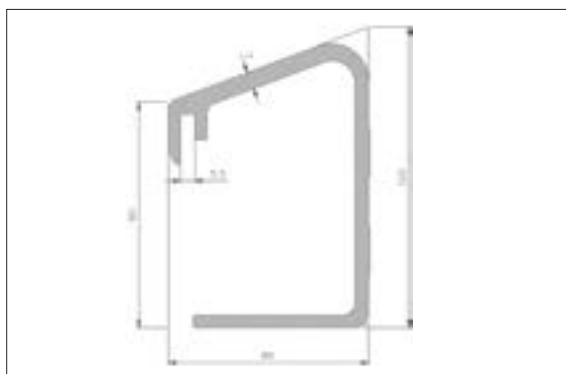

Profilnavn: Topprofil  
Profilnr.: XTR 467  
Vekt: 4,42 kg/m

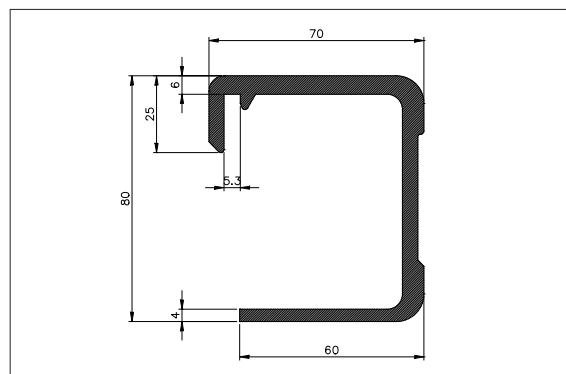

Profilnavn: Topprofil  
Profilnr.: 4T-186  
Vekt: 3,10 kg/m

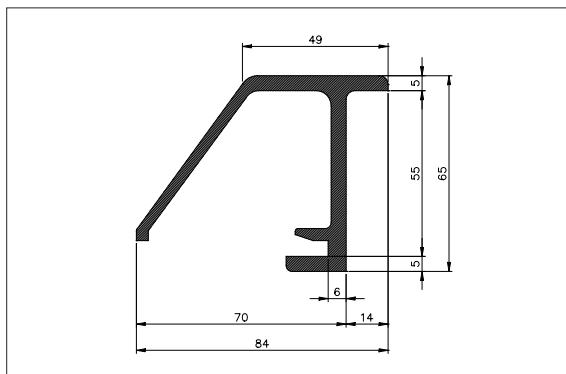

Profilnavn: Endepofil  
Profilnr.: 4T-704  
Vekt: 2,30 kg/m

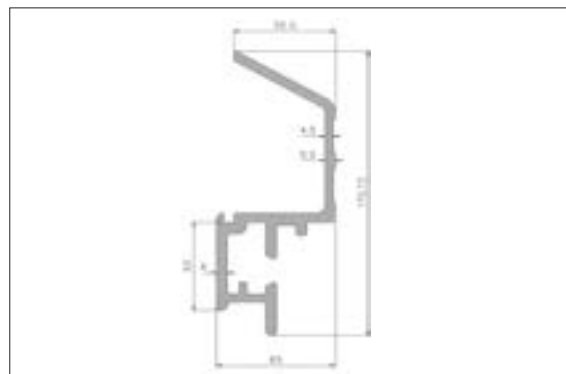

Profilnavn: Bunnprofil  
Profilnr.: XTR 471  
Vekt: 5,04 kg/m

## TILBEHØR TIPPLEMMER

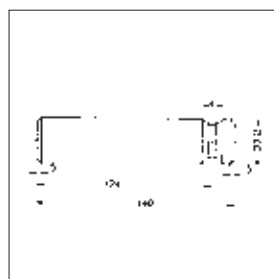
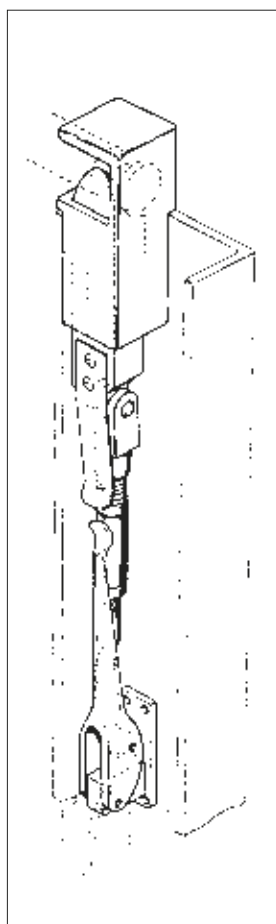
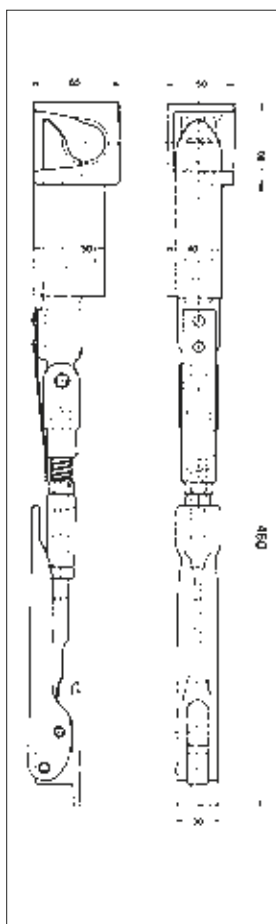

Profilnavn: Pendelbolt

Profilnr.: H 11

Vekt: 0,90 kg/stk.

Profilnavn: Tipllemlås

H 11/55 Venstre

H 11/55 Høyre

H 11/55 Venstre bak

H 11/55 Høyre bak

Vekt: 2,80 kg/stk.

Monteringsanvisning

## SKAPPÅBYGG PROFILER

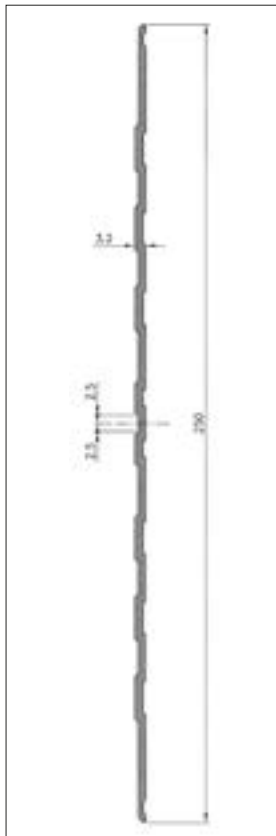

Profilnavn: Sparkelister  
til skap  
Profilnr.: K26927  
Vekt: 1,59 kg/m

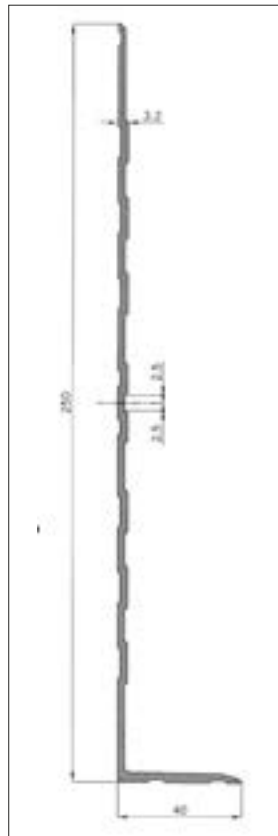

Profilnavn: Sparkelister  
wtil skap  
Profilnr.: K26928  
Vekt: 1,87 kg/m

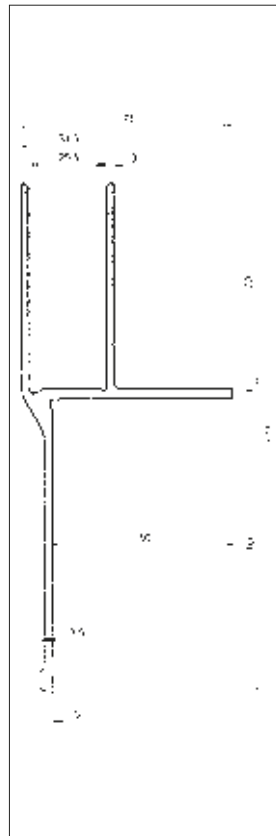

Profilnavn: Kantramme  
Profilnr.: K18783  
Vekt: 2,93 kg/m

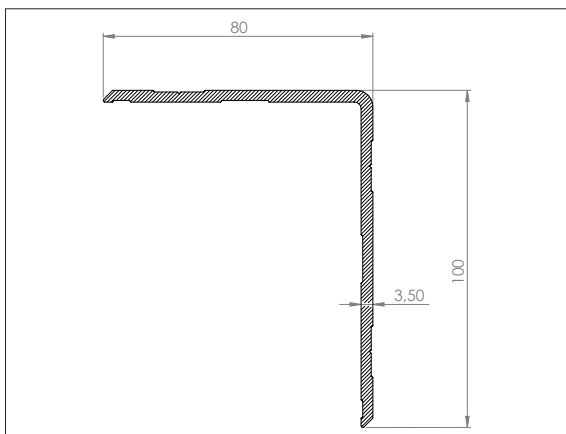

Profilnavn: Hjørneprofil  
Profilnr.: 4T-807  
Vekt: 1,52 kg/m

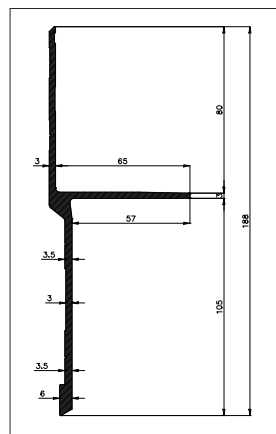

Profilnavn: Kantramme  
Profilnr.: 4T-808  
Vekt: 2,28 kg/m

## VANNLIST OG PAKNING FOR BAKLØFTER

- Vannlist lagerføres i lengder à 2600 mm, eloksert.
- Pakningsprofil lagerføres i lengder à 5100 mm.
- Gummipakning lagerføres i standard ruller à 25 m.
- Meget prisgunstig!

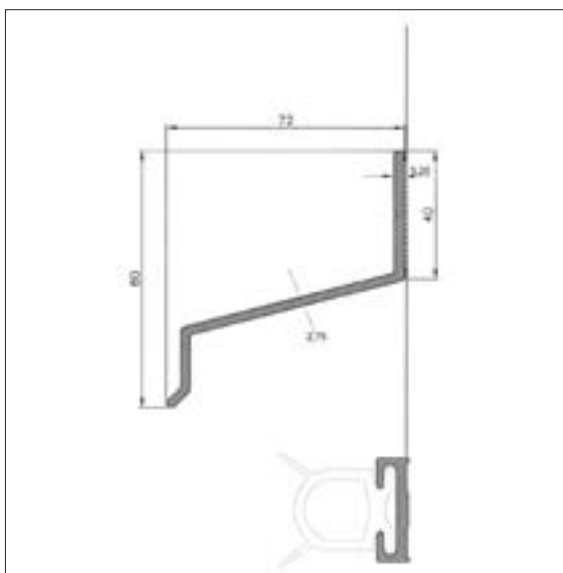
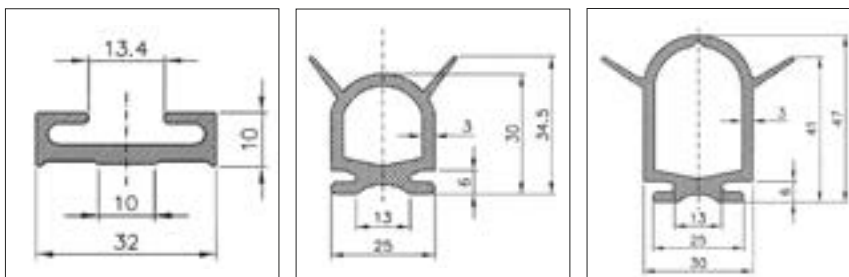

Profilnavn: XTR 5409

## SIDEHINDER / UNDERKJØRINGSHINDER

### Eloksert

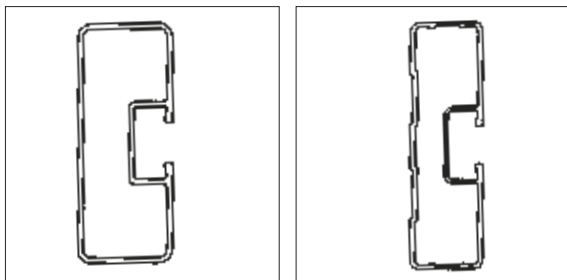

Profilnavn: K19378  
 $ly = 164762 \text{ mm}^4$

Profilnavn: 4T-832  
 $ly = 107511 \text{ mm}^4$

### Aluminium Sidehinder

For sidemontering.

Profilene er eloksert, og kan leveres ferdig kappet.

- Stabil og solid, også egnet til større kjøretøyer.
- Korrosjonsbestandig.
- Enkel og rask montering.
- Mønsterbeskyttet innfesting.

### Dokumentasjon av beregninger

Astrup sidehinderprofil K19378 og 4T-832 oppfyller kravet i direktivet 89/297/EØF om sidehinder på kjøretøy. Beregnet ih.h.t. ECE-reg. nr. 73, avsnitt 7.8.

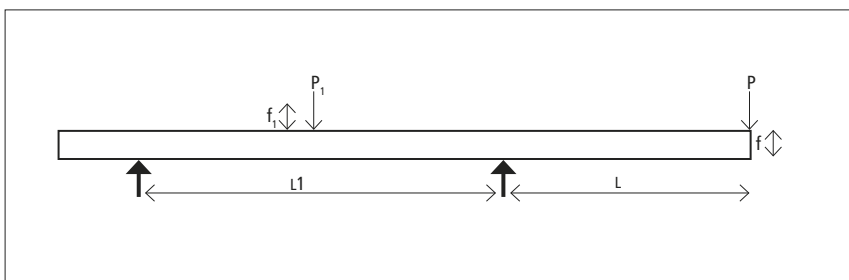

#### K19378

Følgende maksimale avstander tillates:

Mellom innfestningspunkt:

$$L_1 = 4363 \text{ mm}$$

Fra innfestningspunkt til fri profilende:

$$L = 464 \text{ mm}$$

$$f_1 = \frac{P_1 l^3}{E I x 48}$$

$$150 = \frac{P_1 l^3}{E I x 48}$$

$$L_1 = 4363 \text{ mm}$$

$$f = \frac{P (l+c)c^2}{E I x 3}$$

$$30 = \frac{P (l+c)c^2}{E I x 3}$$

$$L = 464 \text{ mm}$$

#### 4T-832

Følgende maksimale avstander tillates:

Mellom innfestningspunkt:

$$L_1 = 3784 \text{ mm}$$

Fra innfestningspunkt til fri profilende:

$$L = 402 \text{ mm}$$

$$f_1 = \frac{P_1 l^3}{E I x 48}$$

$$150 = \frac{P_1 l^3}{E I x 48}$$

$$L_1 = 3784 \text{ mm}$$

$$f = \frac{P (l+c)c^2}{E I x 3}$$

$$30 = \frac{P (l+c)c^2}{E I x 3}$$

$$L = 402 \text{ mm}$$

## Eloksert

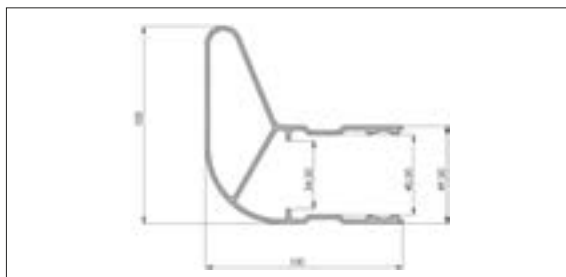

Profilnavn: Endeprofil  
 Profilnr.: K 19236  
 Vekt: 2,14 kg/m

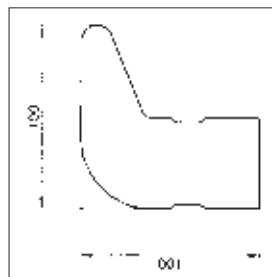

Profilnavn: Deksel, høyre  
 og venstre  
 (over/under)  
 side til K 19236

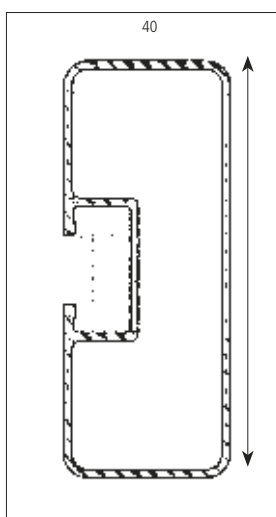

Profilnavn: Sidehinderprofil  
 Profilnr.: K19378  
 Vekt: 1,99 kg/m

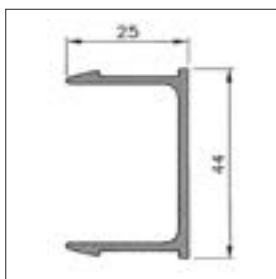
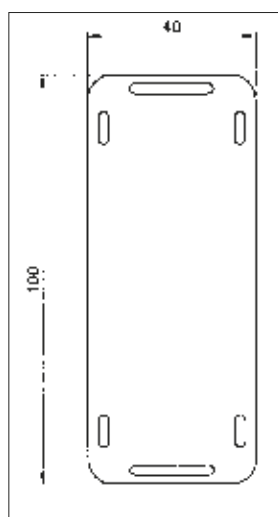

Profilnavn: Dekklisprofil  
 Profilnr.: K16240  
 Vekt: 0,48 kg/m



Profilnavn: Endelukk til  
 K19378

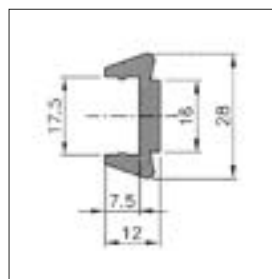

Profilnavn: Skruholderprofil  
 Profilnr.: K16241  
 Vekt: 0,44kg/m  
 Passer for skrue M10  
 For K19378 og 4T-832



## Eloksert

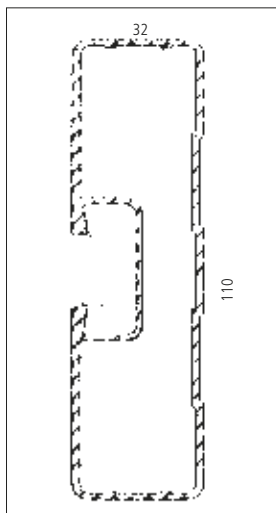

Profilnavn: Sidehinderprofil  
Profilnr.: 4T-832  
Vekt: 1,75 kg/m

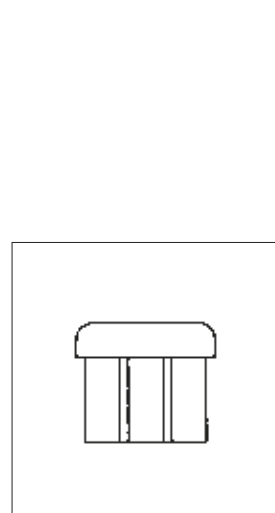
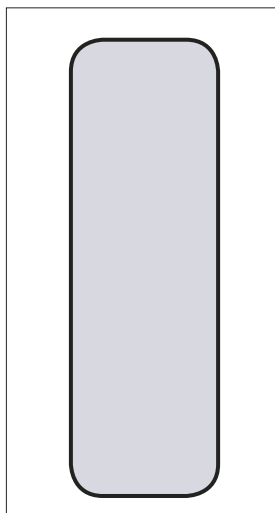

Profilnavn: Endelokk til  
Profilnr.: 4T-832

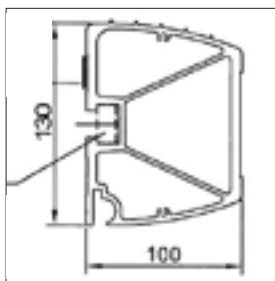

### **Aluminium underkjøringshinder, eloksert**

Godkjent i henhold til EU direktiv CE70/221/CEE inkl. tillegg 2006/96/CE  
Leveres med 2 stk. endelokk i aluminium og 2 stk. gjengende innfestningsdetaljer i rustfritt stål.

Profilnavn: Underkjøringshinder

Profilnr.: J14966  
Vekt: 7,468 kg/m

### Lyktebjelke

- Ferdig kappede lengder
- Vekt 6,25 kg/meter
- Eloksert
- Oppfyller kravene i henhold til ECE dok. Trans/SCI/WP 29/R214 med tillegg nr. 1 og E-EF 79/490 med tillegg 81/333 EEC.

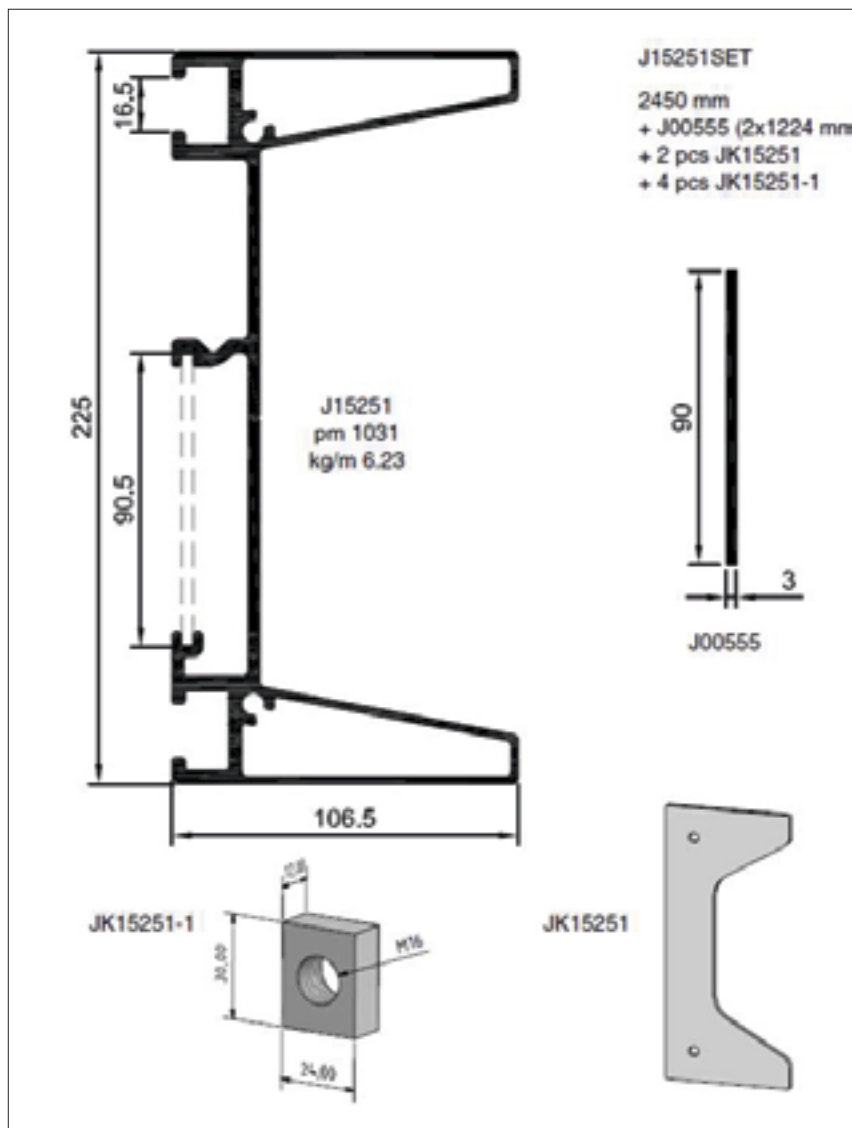



## KJØREBROSYSTEM LA OG LVA

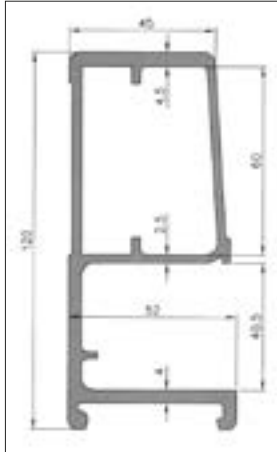

Profilnavn: Kantprofil

Profilnr.: K12896

Vekt: 3,25 kg/m

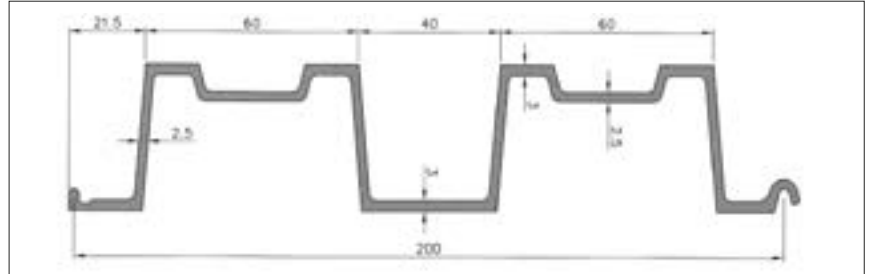

Profilnavn: Bunnprofil

Profilnr.: K12895

Vekt: 2,77 kg/m

### Kjørebros

Kan også leveres med Planbunnprofil K7654, K27231 eller Amplirist istedenfor bunnprofil K12895 (se sidene 89 og 51).

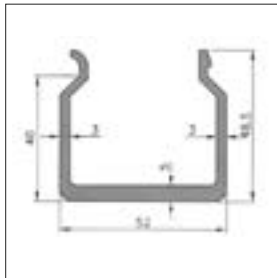

Profilnavn: Forsterkningsprofil

Profilnr.: K12905

Vekt: 1,44 kg/m

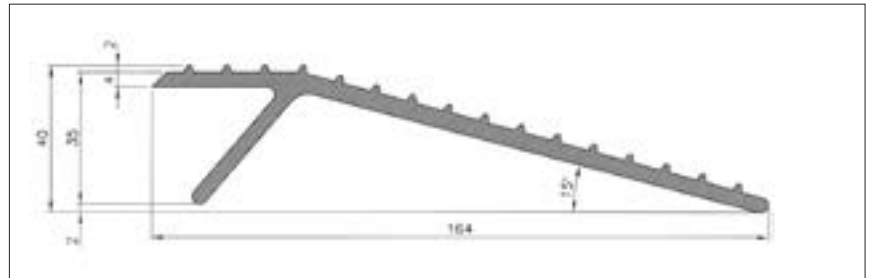

Profilnavn: Entringsprofil

Profilnr.: K12897

Vekt: 2,80 kg/m

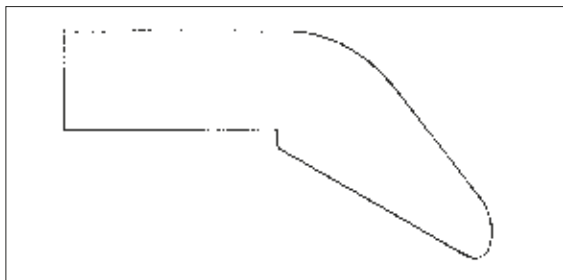

Profilnavn: Konsollplate

Vekt: 0,70 kg/stk.

**Produktdata:**

K12895

Ix = 211800 mm<sup>4</sup>Wx = 10130 mm<sup>3</sup>

K12896

Ix = 1945700 mm<sup>4</sup>Wx = 31940 mm<sup>3</sup>

K12897

Ix = 131300 mm<sup>4</sup>Wx = 6190 mm<sup>3</sup>

K12896+ K12905

Ix = 4726000 mm<sup>4</sup>Wx = 54690 mm<sup>3</sup>**KJØREBRO TYPE LVA (MED FORSTERKET PROFIL)**

Tabellen gjelder for innvendig bredde opp til 500 mm (for begge typer) Type LVA

Lengde mm	Sporbredde (B) og belastning/vekt kg pr. par					
	350 mm		400 mm		500 mm	
	Bel.	Vekt	Bel.	Vekt	Bel.	Vekt
2350	7000	78	5250	82	4200	89
2550	7300	84	5250	88	4200	96
2950	6300	96	5250	100	4200	109
3350	5000	108	5000	113	4200	123
3750	4500	119	4500	125	4200	136
4150	4000	131	4000	137	4000	150
4550	3600	143	3600	150	3600	163
4950	3350	155	3350	162	3350	177
5350	3150	167	3150	175	3150	190

**KJØREBRO TYPE LA (UTEN FORSTERKET PROFIL)**

## Type LA

Lengde mm	Sporbredde (B) og belastning/vekt kg pr. par									
	300 mm		350 mm		400 mm		450 mm		500 mm	
	Bel.	Vekt	Bel.	Vekt	Bel.	Vekt	Bel.	Vekt	Bel.	Vekt
2350	4600	61	4600	65	4600	69	4600	73	4600	76
2550	4000	66	4000	70	4000	74	4000	78	4000	82
2950	3400	75	3400	80	3400	84	3400	89	3400	93
3350	2700	84	2700	89	2700	95	2700	100	2700	105
3750	2400	93	2400	99	2400	105	2400	110	2400	116
4150	2200	102	2200	108	2200	115	2200	121	2200	127
4550	1950	111	1950	118	1950	125	1950	132	1950	139
4950	1800	120	1800	128	1800	135	1800	142	1800	150
5350	1700	130	1700	138	1700	145	1700	153	1700	160
5750	1550	139	1550	148	1550	156	1550	164	1550	173
6150	1400	149	1400	157	1450	166	1400	174	1400	184

Belastningskarakteristikk: To-akslet kjøretøy: Akselavstand = 2500 mm.

Belastningsfordeling P = P1 + P2, P1 = 2/3 P, P2 = 1/3 P.

For en-akslet kjøretøy: P = 0,66 × tabellverdien.



## ØVRIGE PRODUKTER

### Aluminiumdumper

Den beste transportløsningen for kjøring av sand og pukk

For transport av sand, grus og pukk gir aluminiumdumperen klare økonomiske og driftsmessige fordeler. Lav egenvekt gir høyere nyttelast pr. tur og langt billigere tomkjøring, i tillegg til mindre vedlikehold.

#### Brukererfaringene kan kort oppsummeres i 3 punkter:

1. Øket nyttelast pr. tur.
2. Minimalt behov for vedlikehold.
3. Meget enkel å spyle ren.

Aluminiumdumperen kan leveres med 5-8 mm tykke sliteplater i sidene, og 8-12 mm i bunn. Avbildede dumperkasse er levert med luftoperert automatlem og forlengbart drag. Egenvekten er 5.750 kg.

Med 50 mil kjøring hver dag av sand, grus og pukk, ser denne transportøren store fordeler med aluminiumdumperen.



#### Tekniske data

	Bil	Henger
Lengde:	5200 mm	5600 mm
Bredde:	2550 mm	2550 mm
Innv. karmhøyde:	1100 mm	1200 mm
Egenvekt:	–	5.750 kg
Nyttelast:	16.000 kg	18.000 kg

Total nyttelast bil/dumper er 34 tonn, det vil si 4 tonn mere pr. tur sammenlignet med tilsvarende løsning i stål.

#### Eksempel på driftsøkonomi:

Type kjøring:	Sand, grus, pukk
Kjørt distanse:	12000 km
Antall turer:	400
Mernyttelast pr tur:	4 tonn – sammenlignet med ståldumper
Øket nyttelast:	400 tonn – gevinst pr. tonn ca. kr 12,-
Merfortjeneste:	ca. 20.000,-2)

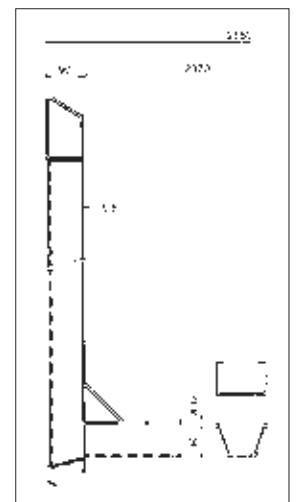

System BW 25 brukes mye i påbygg som vist. Flistransport og dyretransport, i tillegg til vanlig stykkodsplan o.l.

