



Article datasheet

Customer name: CLEARWAY

Reference - product name: HSTS DSS 0984 – Hook on track 984mm 1.2mm

Material: Stainless Steel 201 – Both face polishing

Application / Market: Strip doors

Issue date: 22nd, February 2013

Modification date:

Number :

Datasheet diffusion:

• Direction	• R&D	• Reception / Shipping
• Plant manager	Personnel management	Team leader
Financial & Administrative manager	Accounts department (Customers & Suppliers)	Team leader assistant
• Commercial director	• Purchasing dept.	Operator
Production manager	Maintenance	
• Quality manager	Supply chain	

Distribution list:

J. Valat, S. Vacca, R. Viallis, A. Lasch, P. Bouisset, W. Adams, JM. Chartier, V. Manai, H. Mathieu, J. REY, G. Teissedre, N. Domeny

Cc: P. Chambriard

Modifications	Date	Index#	Writing		Approval	
			Name	visa	Name	visa
Creation	22/02/2013	1	R. Viallis		R. Viallis	
Modification	25/11/2013	2				

Comments: Article changed to match previous one

1. Hook On Track

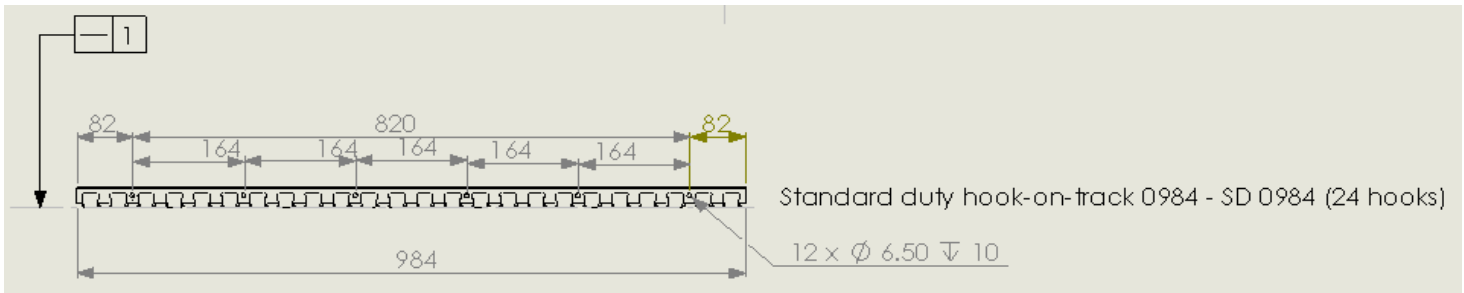

Material thickness : 1.2 mm

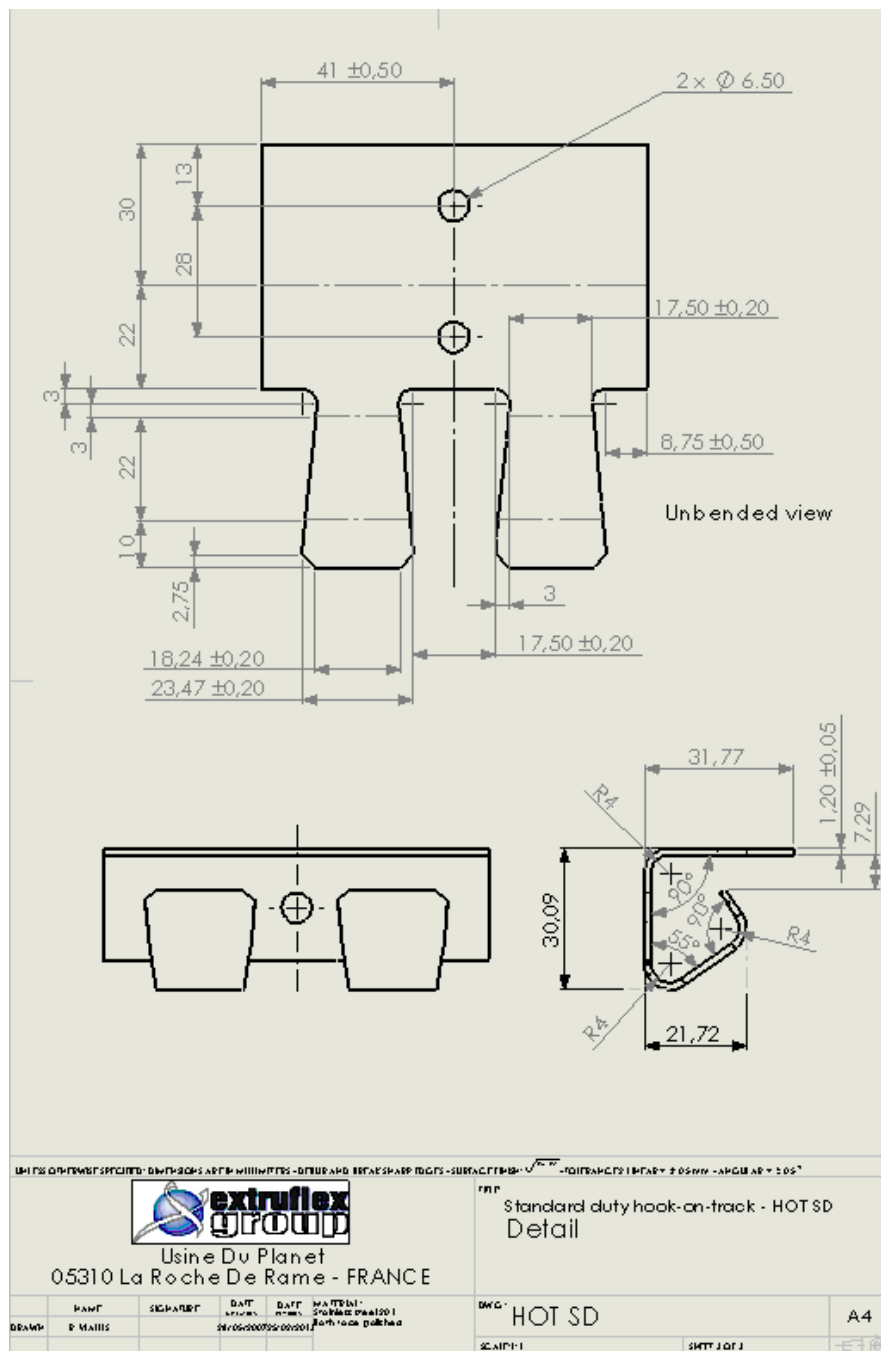

2. Manufacturing Specifications:

Material to be used:

Stainless steel 201 – Both face polishing

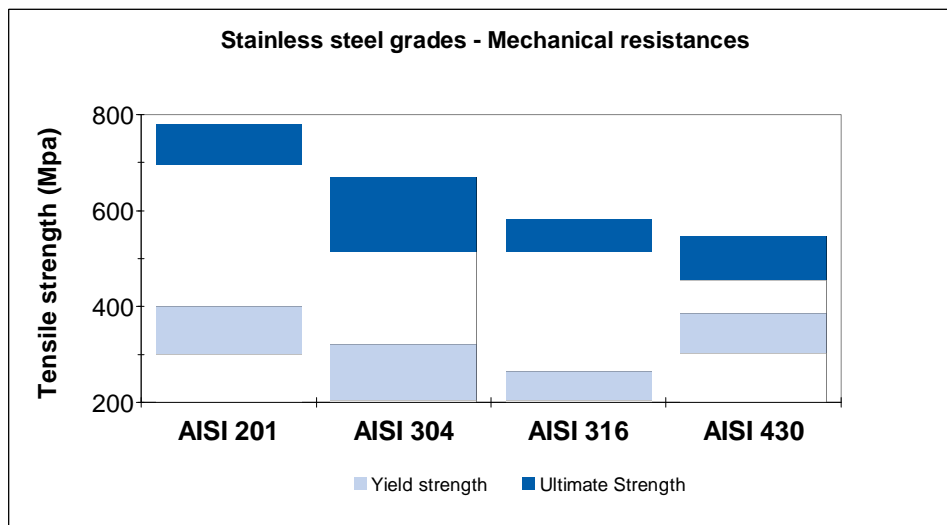
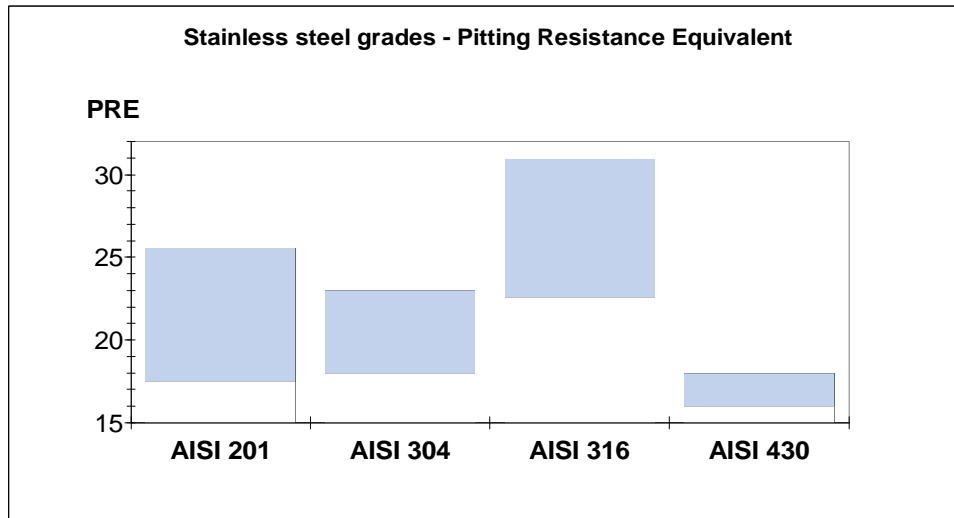

		AISI 201	AISI 304	AISI 316	AISI 430
Corrosion resistance		++	++	+++	+
Mechanical resistance		++	++	++	++

Dimensions & Tolerance:

To be checked on the drawings above

Packaging (Transfer and sales) :

Box	YES	Dimensions: L1000 x l180 x h140	Material : Cardboard Boxes
Quantity	30		
How to			
Water absorber	NO		

Pallet and transport (Transfer):

	Dimensions	Material	Number of box/pallet	Number of box/raw	Net weight	Gross weight
Pallets	1000X1000	Treated wood	42	7	806 Kg	848 Kg

Labels:

A. Top label or printing



Position : Centred on the top of the box

Size : 30mm X 150 mm

B. Side label or printing

DESC : Hook on Track

SIZE : HSTSDSS0984

MATERIAL : STAINLESS STEEL

QTY : 30

NET WEIGHT : 19.2 KG

GROSS WEIGHT : 20.2 KG

CARTON NO : (number of the carton)

POLISHING : YES

Position : On both sides of the boxes (sides 80x115 mm)

Size : 100 X 60 mm

3. QUALITY CHECK

Test	Requirement	Tolerance		Comments
Polishing	No scratches			
Thickness	1.2mm	+0.05	-0.05	
Weight	20.2 Kg Gross weight	-20 grams	+20 grams	